

SA58640

Low-voltage mixer FM IF system

Rev. 01 — 6 April 2005

Product data sheet

1. Introduction

The SA58640 was designed for cordless telephone applications in which efficient and economic integrated solutions are required and yet high performance is desirable. Although the product is not targeted to meet the stringent specifications of high performance cellular equipment, it will exceed the needs for analog cordless phones. The minimal amount of external components and absence of any external adjustments makes for a very economical solution.

2. General description

The SA58640 is a low-voltage monolithic FM IF system incorporating a mixer/oscillator, two limiting intermediate frequency amplifiers, quadrature detector, logarithmic RSSI, voltage regulator and audio and RSSI opamps. The SA58640 is available in a 20-pin SSOP package.

3. Features

- Low power consumption: 5.0 mA typical at 5 V
- Mixer input to >100 MHz
- Mixer conversion power gain of 17 dB at 45 MHz
- Crystal oscillator effective to 100 MHz (LC oscillator or external oscillator can be used at higher frequencies)
- 102 dB of IF amp/limiter gain
- 2 MHz IF amp/limiter small signal bandwidth
- Temperature compensated logarithmic RSSI with a 70 dB dynamic range
- Low external component count; suitable for crystal/ceramic/LC filters
- Audio output internal opamp
- RSSI output internal opamp
- Internal opamps with rail-to-rail outputs
- ESD protection: Human body model 2 kV; robot model 200 V.

4. Applications

- Cordless phones.

PHILIPS

5. Ordering information

Table 1: Ordering information

Type number	Package		Version
	Name	Description	
SA58640DK	SSOP20	plastic shrink small outline package; 20 leads; body width 4.4 mm	SOT266-1

6. Block diagram

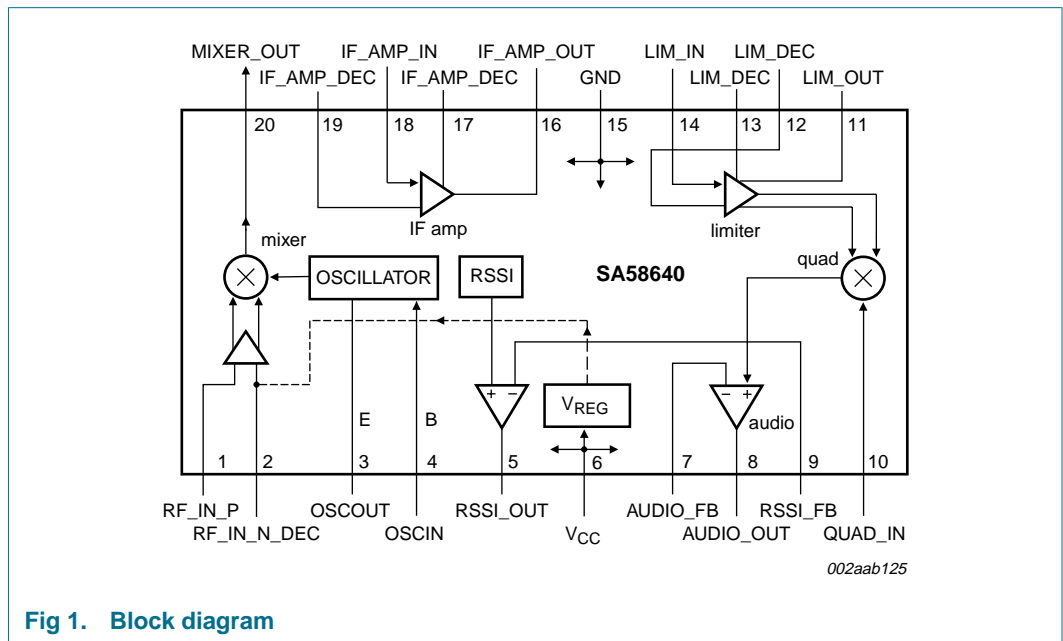

Fig 1. Block diagram

7. Pinning information

7.1 Pinning

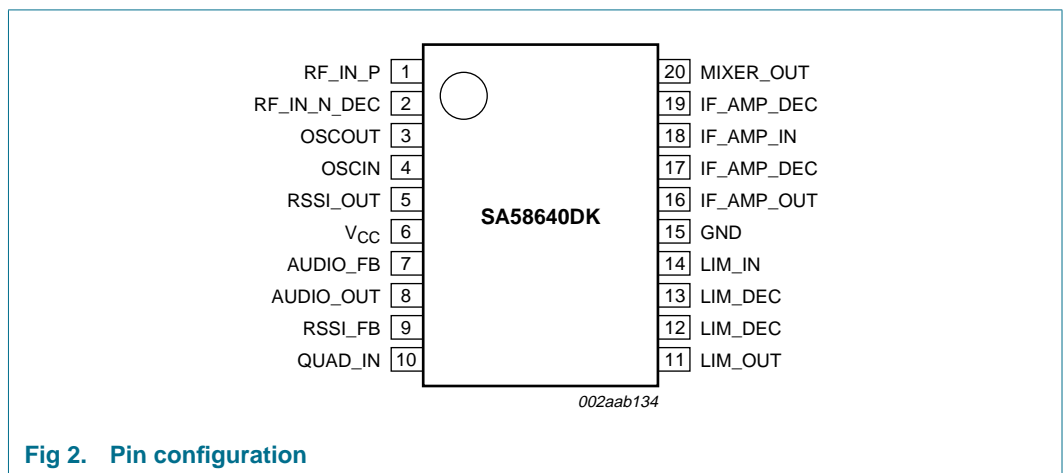

Fig 2. Pin configuration

7.2 Pin description

Table 2: Pin description

Symbol	Pin	Description
RF_IN_P	1	positive RF mixer input
RF_IN_N_DEC	2	negative RF mixer input, decoupling
OSCOU	3	oscillator output (emitter)
OSCIN	4	oscillator input (base)
RSSI_OUT	5	RSSI amplifier output
V _{CC}	6	positive supply
AUDIO_FB	7	audio amplifier negative input, feedback
AUDIO_OUT	8	audio amplifier output
RSSI_FB	9	RSSI amplifier negative input, feedback
QUAD_IN	10	quadrature detector input
LIM_OUT	11	limiter amplifier output
LIM_DEC	12	limiter decoupling
LIM_DEC	13	limiter decoupling
LIM_IN	14	limiter amplifier input
GND	15	ground
IF_AMP_OUT	16	IF amplifier output
IF_AMP_DEC	17	IF amplifier decoupling
IF_AMP_IN	18	IF amplifier input
IF_AMP_DEC	19	IF amplifier decoupling
MIXER_OUT	20	mixer output

8. Functional description

The SA58640 is an IF signal processing system suitable for second IF systems with input frequency as high as 100 MHz. The bandwidth of the IF amplifier and limiter is at least 2 MHz with 90 dB of gain. The gain/bandwidth distribution is optimized for 455 kHz, 1.5 kΩ source applications. The overall system is well-suited to battery operation as well as and high quality products of all types.

The input stage is a Gilbert cell mixer with oscillator. Typical mixer characteristics include a noise figure of 7.0 dB, conversion gain of 17 dB, and input third-order intercept of -10 dBm. The oscillator will operate in excess of 100 MHz in LC tank configurations. Hartley or Colpitts circuits can be used up to 100 MHz for crystal configurations.

The output impedance of the mixer is a 1.5 kΩ resistor permitting direct connection to a 455 kHz ceramic filter. The input resistance of the limiting IF amplifiers is also 1.5 kΩ. With most 455 kHz ceramic filters and many crystal filters, no impedance matching network is necessary. The IF amplifier has 44 dB of gain and 5.5 MHz bandwidth. The IF limiter has 58 dB of gain and 4.5 MHz bandwidth. To achieve optimum linearity of the log signal strength indicator, there must be a 12 dB(V)¹ insertion loss between the first and second IF stages. If the IF filter or interstage network does not cause 12 dB(V) insertion loss, a

1. $\text{dB(V)} = 20 \log V_o/V_i$.

fixed or variable resistor or an L pad for simultaneous loss and impedance matching can be added between the first IF output (pin 16) and the interstage network. The overall gain will then be 90 dB with 2 MHz bandwidth.

The signal from the second limiting amplifier goes to a Gilbert cell quadrature detector. One port of the Gilbert cell is internally driven by the IF. The other output of the IF is AC-coupled to a tuned quadrature network. This signal, which now has a 90° phase relationship to the internal signal, drives the other port of the multiplier cell.

The demodulated output of the quadrature drives an internal opamp. This opamp can be configured as a unity gain buffer, or for simultaneous gain, filtering, and 2nd-order temperature compensation if needed. It can drive an AC load as low as 10 kΩ with a rail-to-rail output.

A log signal strength indicator completes the circuitry. The output range is greater than 70 dB and is temperature compensated. This signal drives an internal opamp. The opamp is capable of rail-to-rail output. It can be used for gain, filtering, or 2nd-order temperature compensation of the RSSI, if needed.

9. Limiting values

Table 3: Limiting values

In accordance with the Absolute Maximum Rating System (IEC 60134).

Symbol	Parameter	Conditions	Min	Max	Unit
V_{CC}	single supply voltage		-	7	V
T_{stg}	storage temperature range		-65	150	°C
T_{amb}	operating ambient temperature range		-40	85	°C
Z_{th}	thermal impedance		-	117	K/W

10. Static characteristics

Table 4: Static characteristics

$T_{amb} = 25\text{ °C}$; $V_{CC} = +5\text{ V}$, unless otherwise stated. [1]

Symbol	Parameter	Conditions	Min	Typ	Max	Unit
V_{CC}	power supply voltage range		4.5	-	6.0	V
I_{CC}	DC current drain		-	5.0	6.0	mA

- [1] RF frequency = 45 MHz; +14.5 dBV RF input step-up; IF frequency = 455 kHz; R17 = 2.4 k Ω and R18 = 3.3 k Ω ; RF level = -45 dBm; FM modulation = 1 kHz with ± 5 kHz peak deviation. Audio output with de-emphasis filter and C-message weighted filter. See [Figure 3 "45 MHz application circuit" on page 7](#). The parameters listed above are tested using automatic test equipment to assure consistent electrical characteristics. The limits do not represent the ultimate performance limits of the device. Use of an optimized RF layout will improve many of the listed parameters.

11. Dynamic characteristics

Table 5: Dynamic characteristics

Symbol	Parameter	Conditions	Min	Typ	Max	Unit	
Mixer/oscillator section (external LO = 220 mV_{RMS})							
f_{in}	input frequency		-	100	-	MHz	
f_{osc}	crystal oscillator frequency		-	100	-	MHz	
	noise figure at 45 MHz		-	7.0	-	dB	
	third-order input intercept point (50 Ω source)	$f_1 = 45.0$; $f_2 = 45.06$ MHz Input RF level = -52 dBm	-	-10	-	dBm	
$P_{G(conv)}$	conversion power gain	matched 14.5 dBV step-up	10	17	-	dB	
		50 Ω source	-	+2.5	-	dB	
$R_{i(RF)}$	RF input resistance	single-ended input	-	8	-	k Ω	
$C_{i(RF)}$	RF input capacitance		-	3.0	4.0	pF	
$R_{o(mix)}$	mixer output resistance	measured on pin 20	1.25	1.5	-	k Ω	
IF section							
$G_{a(IF)}$	IF amp gain	50 Ω source	-	44	-	dB	
L_G	limiter gain	50 Ω source	-	58	-	dB	
	AM rejection	30 % AM 1 kHz	-	50	-	dB	
	audio level	gain of two	60	120	-	mV	
	SINAD sensitivity	IF level = -110 dBm	-	17	-	dB	
THD	total harmonic distortion		-	-55	-	dB	
S/N	signal-to-noise ratio	no modulation for noise	-	60	-	dB	
		IF RSSI output, $R_9 = 2$ k Ω [1]	IF level = -110 dBm	-	0.5	1.0	V
		IF level = -50 dBm	-	1.7	2.4	V	
	RSSI range		-	60	-	dB	
$Z_{i(IF)}$	IF input impedance	measured on pin 18	1.3	1.5	-	k Ω	
$Z_{o(IF)}$	IF output impedance	measured on pin 16	-	0.3	-	k Ω	
$Z_{i(lim)}$	limiter input impedance	measured on pin 14	1.3	1.5	-	k Ω	
$Z_{o(lim)}$	limiter output impedance	measured on pin 11	-	0.3	-	k Ω	
$V_{o(lim)(rms)}$	limiter output voltage	measured on pin 11	-	130	-	mV	
RF/IF section (internal LO)							
	system SINAD sensitivity	RF level = -110 dBm	-	12	-	dB	

[1] The generator source impedance is 50 Ω , but the SA58640 input impedance at pin 18 is 1500 Ω . As a result, IF level refers to the actual signal that enters the SA58640 IF amplifier input (pin 18) which is about 21 dB less than the 'available power' at the generator.

12. Application information

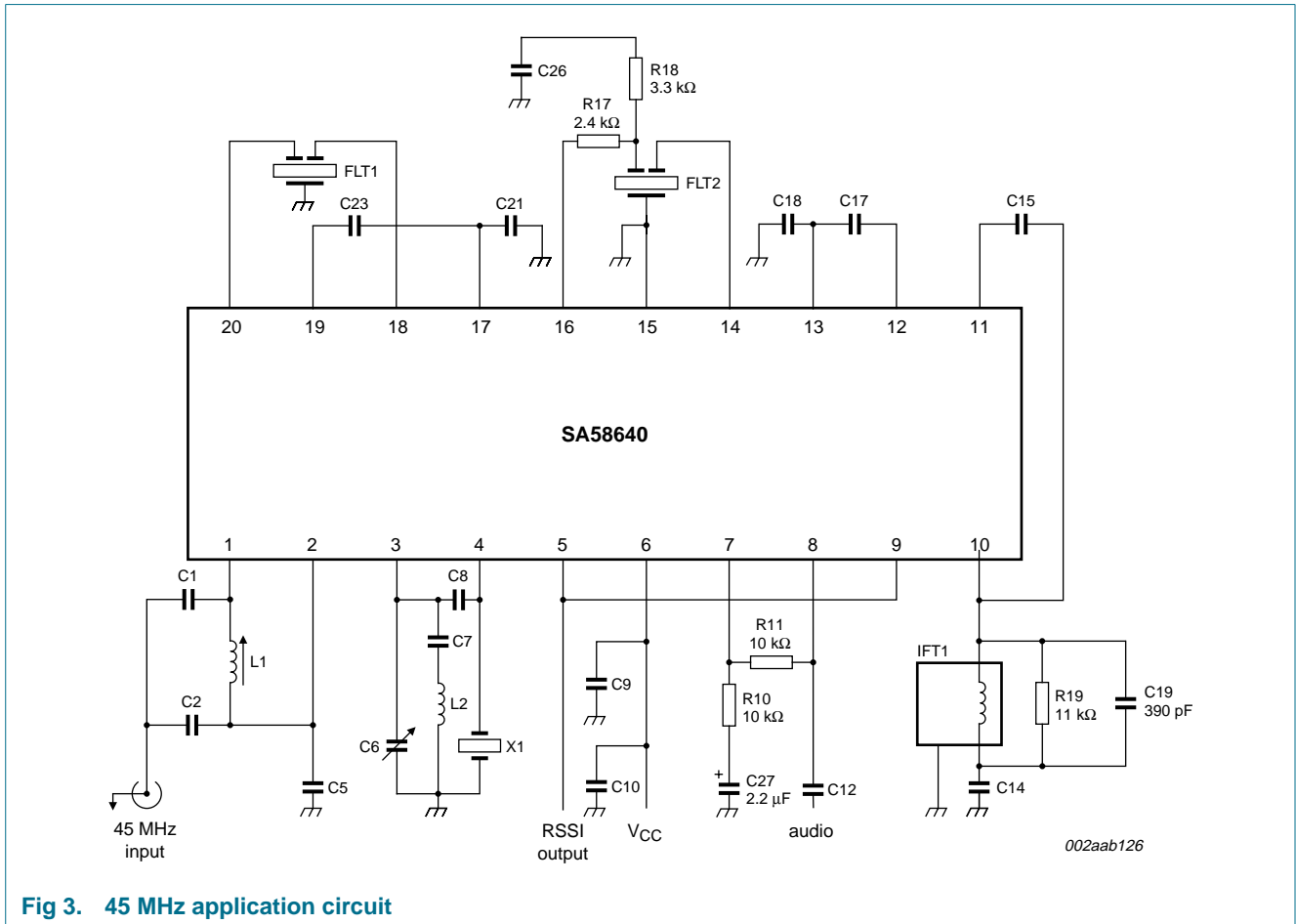

Fig 3. 45 MHz application circuit

Table 6: Demo board application component list

Component	Value	Type
C1	51 pF	NPO ceramic
C2	220 pF	NPO ceramic
C5	100 nF ± 10 %	monolithic ceramic
C6	5 pF to 30 pF	trim cap
C7	1 nF	ceramic
C8	10.0 pF	NPO ceramic
C9	100 nF ± 10 %	monolithic ceramic
C10	10 μF	tantalum (minimum) ^[1]
C12	2.2 μF ± 10 %	tantalum
C14	100 nF ± 10 %	monolithic ceramic
C15	10 pF	NPO ceramic
C17	100 nF ± 10 %	monolithic ceramic
C18	100 nF ± 10 %	monolithic ceramic
C19	390 pF ± 10 %	monolithic ceramic

Table 6: Demo board application component list ...continued

Component	Value	Type
C21	100 nF ± 10 %	monolithic ceramic
C23	100 nF ± 10 %	monolithic ceramic
C26	100 nF ± 10 %	monolithic ceramic
C27	2.2 µF	tantalum
FLT1	-	ceramic filter Murata CFUCF455KB4X-R0 or equivalent
FLT2	-	ceramic filter Murata CFUCF455KB4X-R0 or equivalent
IFT1	330 µH	TOKO 836AN-0129Z
L1	330 nH	TOKO A638AN-0158Z
L2	1.2 µH nominal	FSLM2520-12K
X1	44.545 MHz	crystal ICM4712701
R5	not used in application board (see list item 8 on page 9)	-
R10	8.2 kΩ ± 5 %	¼ W carbon composition
R11	10 kΩ ± 5 %	¼ W carbon composition
R17	2.4 kΩ ± 5 %	¼ W carbon composition
R18	3.3 kΩ ± 5 %	¼ W carbon composition
R19	11 kΩ ± 5 %	¼ W carbon composition

[1] This value can be reduced when a battery is the power source.

13. Test information

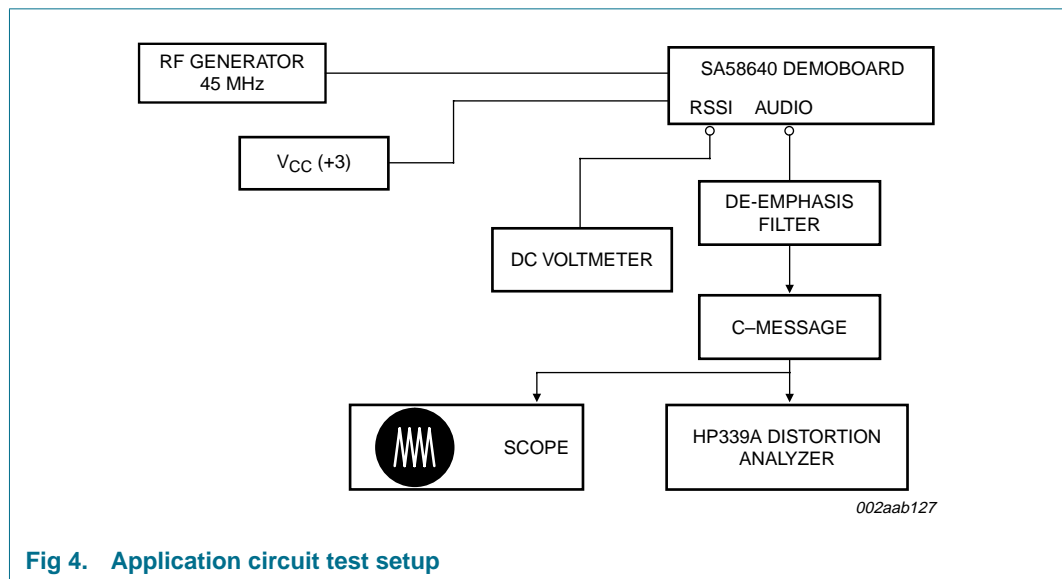

Fig 4. Application circuit test setup

The following list items [1](#) through [8](#) apply to [Figure 4](#):

1. The C-message and de-emphasis filter combination has a peak gain of 10 for accurate measurements. Without the gain, the measurements may be affected by the noise of the scope and HP339A analyzer. The de-emphasis filter has a fixed -6 dB/Octave slope between 300 Hz and 3 kHz.
2. The ceramic filters can be 30 kHz SFG455A3s made by Murata which have 30 kHz IF bandwidth (they come in blue), or 16 kHz CFU455Ds, also made by Murata (they come in black). All specifications and testing are done with the wideband filter.
3. Set your RF generator at 45.000 MHz, use a 1 kHz modulation frequency and a 6 kHz deviation if you use 16 kHz filters, or 8 kHz if you use 30 kHz filters.
4. The measured typical sensitivity for 12 dB SINAD should be $0.45 \mu\text{V}$ or -114 dBm at the RF input.
5. The layout is very critical in the performance of the receiver. We highly recommend our demo board layout.
6. The smallest RSSI voltage (i.e., when no RF input is present and the input is terminated) is a measure of the quality of the layout and design. If the lowest RSSI voltage is 500 mV or higher, it means the receiver is in regenerative mode. In that case, the receiver sensitivity will be worse than expected.
7. All of the inductors, the quad tank, and their shield must be grounded. A $10 \mu\text{F}$ to $15 \mu\text{F}$ or higher value tantalum capacitor on the supply line is essential. A low frequency ESR screening test on this capacitor will ensure consistent good sensitivity in production. A $0.1 \mu\text{F}$ bypass capacitor on the supply pin V_{CC} , and grounded near the 44.545 MHz oscillator improves sensitivity by 2 dB to 3 dB.
8. R5 can be used to bias the oscillator transistor at a higher current for operation above 45 MHz. Recommended value is $22 \text{ k}\Omega$, but should not be below $10 \text{ k}\Omega$.

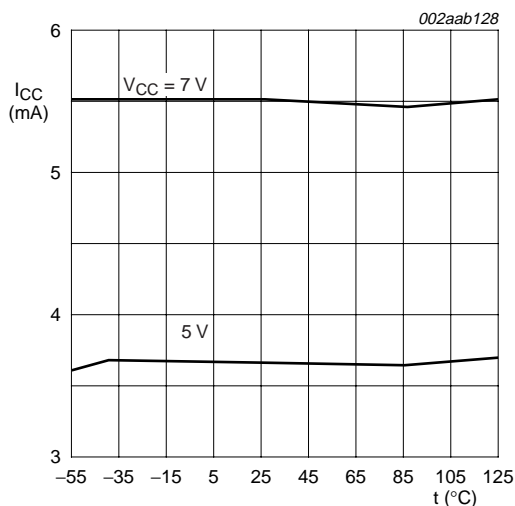
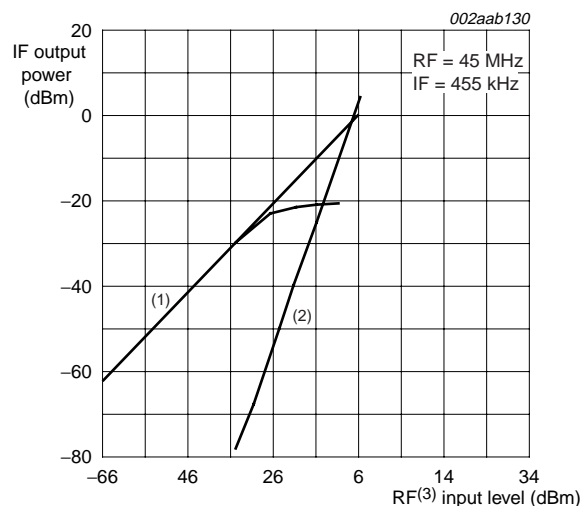
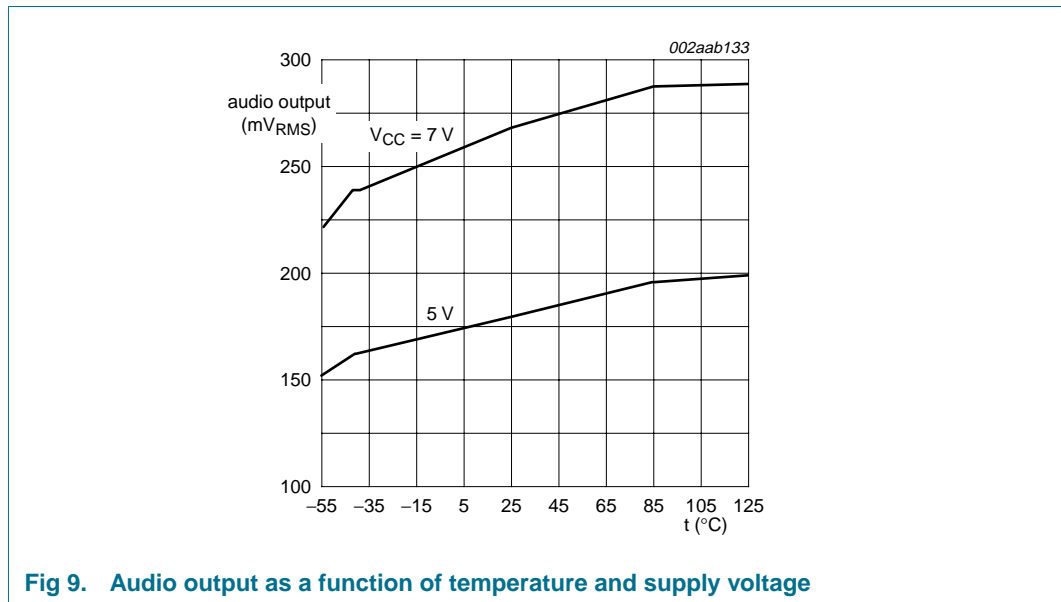
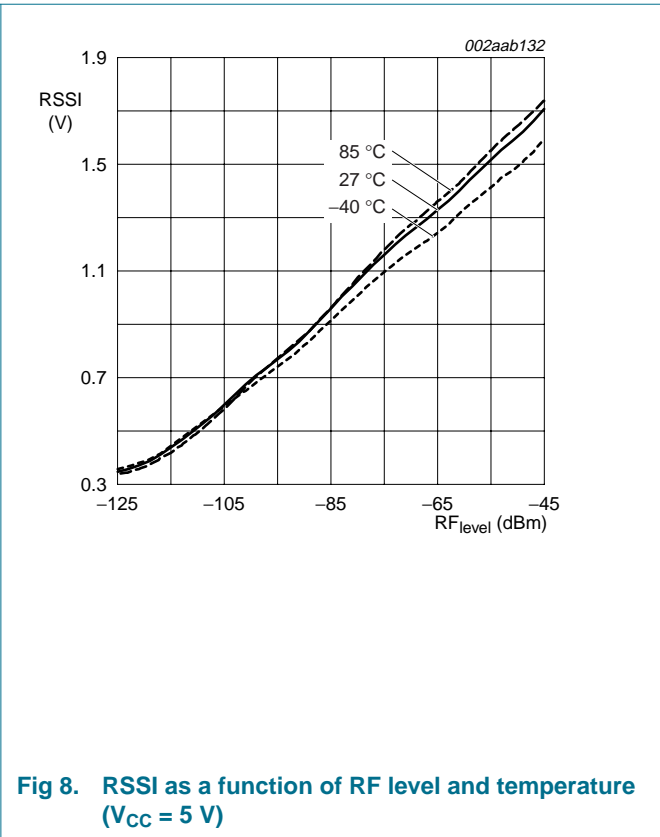
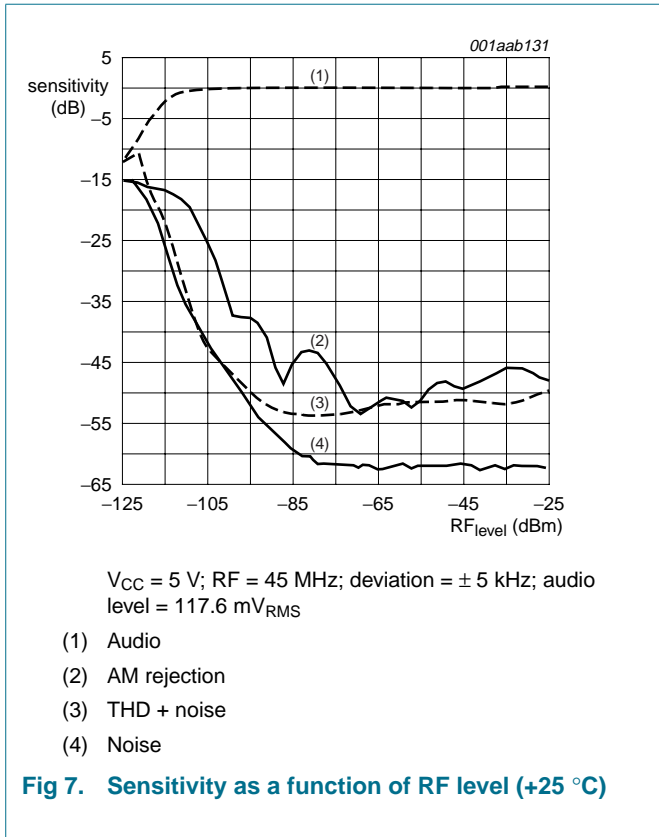

Fig 5. I_{CC} as a function of temperature and supply voltage



- (1) Fund product
- (2) 3rd order product
- (3) 50Ω input

Fig 6. Mixer third order intercept and compression



14. Package outline

SSOP20: plastic shrink small outline package; 20 leads; body width 4.4 mm

SOT266-1

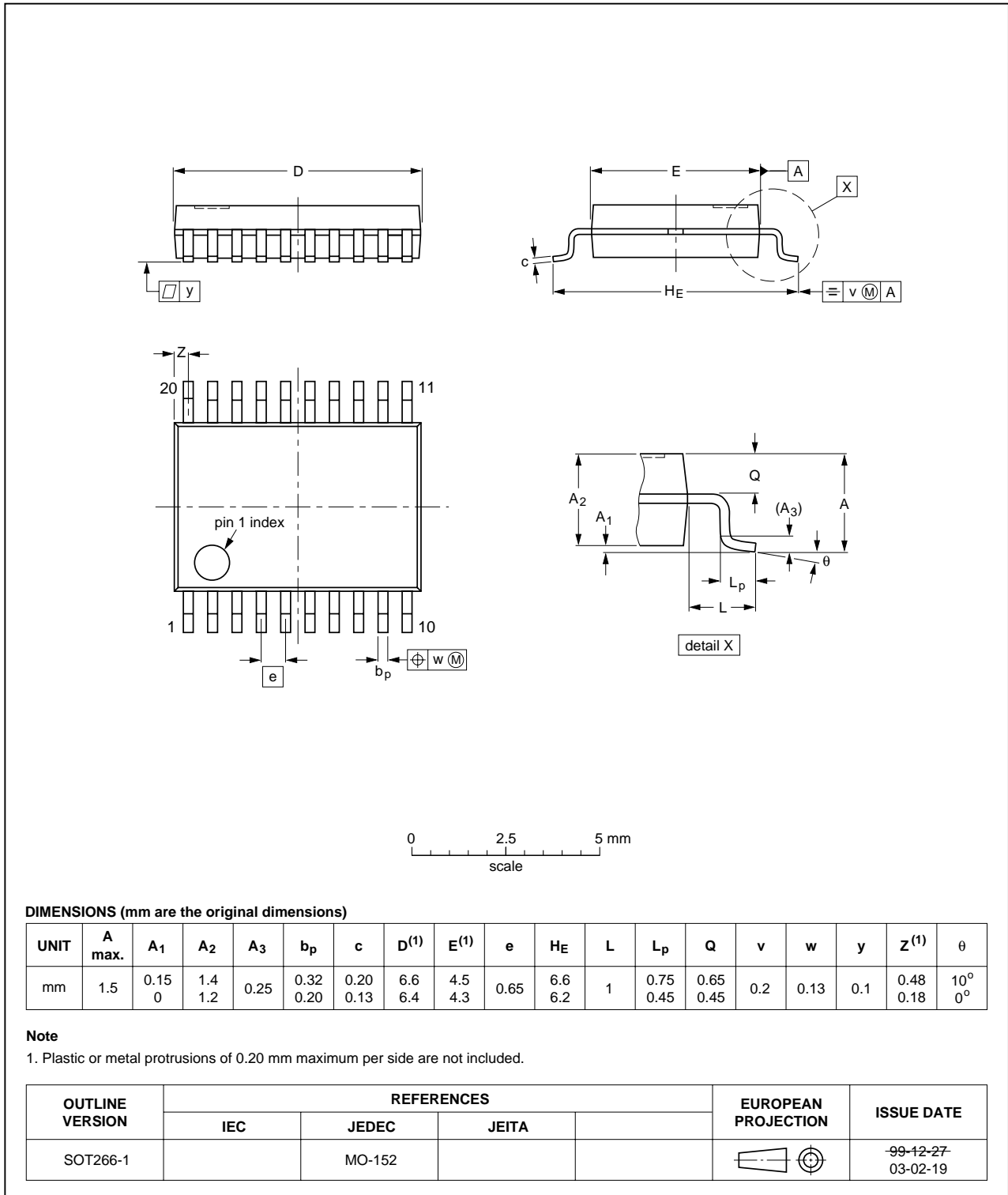

Fig 10. Package outline SOT266-1 (SSOP20)

15. Abbreviations

Table 7: Abbreviations

Acronym	Description
AC	Alternating Current
AM	Amplitude Modulation
ESD	Electrostatic Discharge
ESR	Equivalent Series Resistance
FM	Frequency Modulator
IF	Intermediate Frequency
LO	Local Oscillator
RF	Radio Frequency
RSSI	Received Signal Strength Indicator
SINAD	Signal-to-Noise And Distortion ratio
SSOP	Shrink Small Outline Package
THD	Total Harmonic Distortion

16. Revision history

Table 8: Revision history

Document ID	Release date	Data sheet status	Change notice	Doc. number	Supersedes
SA58640_1	20050406	Product data sheet	-	9397 750 14161	-

17. Data sheet status

Level	Data sheet status ^[1]	Product status ^[2] ^[3]	Definition
I	Objective data	Development	This data sheet contains data from the objective specification for product development. Philips Semiconductors reserves the right to change the specification in any manner without notice.
II	Preliminary data	Qualification	This data sheet contains data from the preliminary specification. Supplementary data will be published at a later date. Philips Semiconductors reserves the right to change the specification without notice, in order to improve the design and supply the best possible product.
III	Product data	Production	This data sheet contains data from the product specification. Philips Semiconductors reserves the right to make changes at any time in order to improve the design, manufacturing and supply. Relevant changes will be communicated via a Customer Product/Process Change Notification (CPCN).

[1] Please consult the most recently issued data sheet before initiating or completing a design.

[2] The product status of the device(s) described in this data sheet may have changed since this data sheet was published. The latest information is available on the Internet at URL <http://www.semiconductors.philips.com>.

[3] For data sheets describing multiple type numbers, the highest-level product status determines the data sheet status.

18. Definitions

Short-form specification — The data in a short-form specification is extracted from a full data sheet with the same type number and title. For detailed information see the relevant data sheet or data handbook.

Limiting values definition — Limiting values given are in accordance with the Absolute Maximum Rating System (IEC 60134). Stress above one or more of the limiting values may cause permanent damage to the device. These are stress ratings only and operation of the device at these or at any other conditions above those given in the Characteristics sections of the specification is not implied. Exposure to limiting values for extended periods may affect device reliability.

Application information — Applications that are described herein for any of these products are for illustrative purposes only. Philips Semiconductors make no representation or warranty that such applications will be suitable for the specified use without further testing or modification.

19. Disclaimers

Life support — These products are not designed for use in life support appliances, devices, or systems where malfunction of these products can reasonably be expected to result in personal injury. Philips Semiconductors customers using or selling these products for use in such applications do so at their own risk and agree to fully indemnify Philips Semiconductors for any damages resulting from such application.

Right to make changes — Philips Semiconductors reserves the right to make changes in the products - including circuits, standard cells, and/or software - described or contained herein in order to improve design and/or performance. When the product is in full production (status 'Production'), relevant changes will be communicated via a Customer Product/Process Change Notification (CPCN). Philips Semiconductors assumes no responsibility or liability for the use of any of these products, conveys no license or title under any patent, copyright, or mask work right to these products, and makes no representations or warranties that these products are free from patent, copyright, or mask work right infringement, unless otherwise specified.

20. Contact information

For additional information, please visit: <http://www.semiconductors.philips.com>

For sales office addresses, send an email to: sales.addresses@www.semiconductors.philips.com

21. Contents

1	Introduction	1
2	General description	1
3	Features	1
4	Applications	1
5	Ordering information	2
6	Block diagram	2
7	Pinning information	2
7.1	Pinning	2
7.2	Pin description	3
8	Functional description	3
9	Limiting values	5
10	Static characteristics	5
11	Dynamic characteristics	6
12	Application information	7
13	Test information	9
14	Package outline	12
15	Abbreviations	13
16	Revision history	14
17	Data sheet status	15
18	Definitions	15
19	Disclaimers	15
20	Contact information	15



© Koninklijke Philips Electronics N.V. 2005

All rights are reserved. Reproduction in whole or in part is prohibited without the prior written consent of the copyright owner. The information presented in this document does not form part of any quotation or contract, is believed to be accurate and reliable and may be changed without notice. No liability will be accepted by the publisher for any consequence of its use. Publication thereof does not convey nor imply any license under patent- or other industrial or intellectual property rights.

Date of release: 6 April 2005
Document number: 9397 750 14161

Published in The U.S.A.